

**NML.../SH/T Connectors**

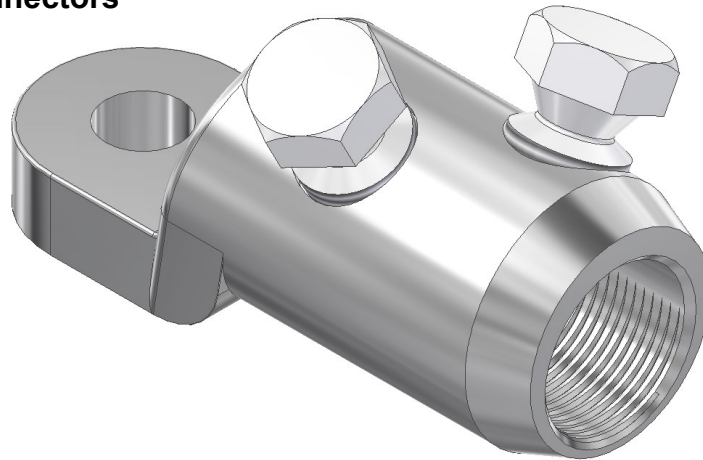

**Principle Application:**

Termination of sector shaped stranded or solid cored conductors.

**Range:**

Product Reference (Part Number)	Core C.S.A. (mm <sup>2</sup> )		Stud Size	
	Min	Max	Metric	Imperial
NML1-12/SH/T (51907-11)	50	95	M12	1/2"
NML1-16/SH/T (51907-09)			M16	5/8"
NML2-12/SH/T (51907-10)	120	185	M12	1/2"
NML2-16/SH/T (51907-12)			M16	5/8"
NML3-12/SH/T (51907-13)	240	300	M12	1/2"
NML3-16/SH/T (51907-14)			M16	5/8"

Note: For jointing other core configurations/sizes please contact Sicame Engineering Dept

The **Sicame** 'NML' range of mechanical lugs has been designed as a practical alternative to crimping or sweating methods, thereby offering the following advantages: -

- a. Terminations can be jointed using simple hand tools, therefore specialised tooling or sweating skills are not required.
- b. The bolted connection to the busbar, or any other equipment, can be accurately located before the conductor is finally secured within the barrel of the lug, thereby avoiding any problems of elongation and axial alignment.

**NML.../SH/T Connectors**

**Physical Dimensions**

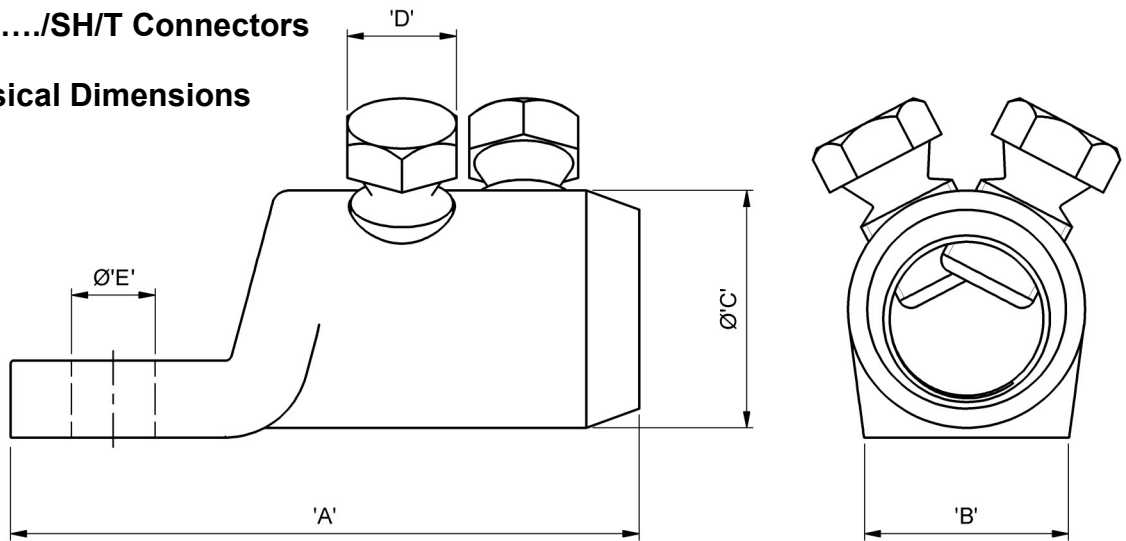

Product Reference	Dimensions (mm)				
	'A'	'B'	'ØC'	'D' A/F	'ØE'
NML1-12/SH/T (51907-11)	88.0	28.0	28.0	17.0	
NML1-16/SH/T (51907-09)					
NML2-12/SH/T (51907-10)	98.0	32.0	37.0	17.0	
NML2-16/SH/T (51907-12)					
NML3-12/SH/T (51907-13)	98.0	32.0	41.0	17.0	
NML3-16/SH/T (51907-14)					

**Material:**

Aluminium Alloy

**Test Specification:**

Designed to meet the requirements of BS EN 61238-1.

**Fitting Instructions:**

- Strip insulation from core equal to length of barrel + 5mm.
- Thoroughly abrade exposed conductors.
- Wrap brass gauze around any copper conductors within the connector.
- Slacken screws and fit lug over core.
- Tighten screws consecutively one turn at a time until the heads have sheared.