

TW Washers

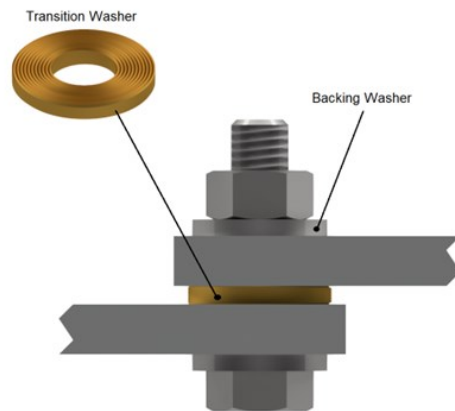

Principle Application

Bolted joint interfaces eg: busbars.

Reference Code (Part Number)	Size Metric	Size Imp
TW1/1 (51809-42)	M6	1/4"
TW1/2 (53485-97)	M8	5/16"
TW1/3 (2172-166)	M10	3/8"
TW1/4 (53485-49)	M12	1/2"
TW1/5 (53485-50)	M16	5/8"
TW1/6	M20	3/4"

The bolted joint transition washer, designed and developed by the Central Electricity Research Laboratories, is manufactured by Sicame UK.

The device consists of a sharply profiled copper alloy washer. When inserted between the mating faces of a bolted joint the sharp profile penetrates surface oxide films. Special backing washers are also supplied to ensure an even distribution of the clamping load at the interface.

Designed primarily for aluminium conductors, the washer provides a stable corrosion-resistant interface between aluminium and other metals, such as copper or tinned copper. It enables bolted electrical joints to be rapidly assembled without the requirement for extensive preparation. The electrical and physical stability of the washer offers a significant improvement in reliability over traditionally abraded interfaces, and effectively prevents thermal runaway and ultimate breakdown.

The transition washers are supplied coated with Millers 184A, surface protection oil complete with the correct backing washers. Assembly instructions are given overleaf.

TW Washers

Physical Dimensions

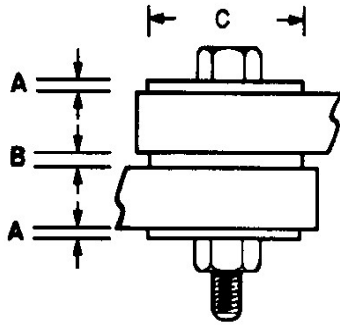

Reference Code (Part Number)	Size Metric	Dimensions (mm)			Bolt Torque Nm	Gross Weight (gms) per 100
		A	B	C		
TW1/1 (51809-42)	6	2.0	2.0	14.0	7	670
TW1/2 (53485-97)	8	2.2	2.5	21.0	20	1620
TW1/3 (2172-166)	10	2.4	2.5	24.0	35	2190
TW1/4 (53485-49)	12	3.0	2.5	28.0	50	3440
TW1/5 (53485-50)	16	3.4	2.5	34.0	90	5160
TW1/6	20	4.0	2.5	40.0	150	7400

Material

Transition Washer: Corrosion resistant copper alloy to BS 2874 CZ 121.

Backing Washer: Protected steel to specification.

Fitting Instructions

Ensure that the surfaces to be connected are free from impurities. Although it is not necessary to abrade or file the surfaces, abnormal deposits of corrosion or contaminant should be removed. Locate the appropriate size of transition washer between the mating surfaces and assemble the joint, together with the backing washers, in accordance with the sketch overleaf. It is recommended that grade 8.8 steel bolts should be used and the assembly tightened with a torque spanner set to the appropriate value listed in the table above.

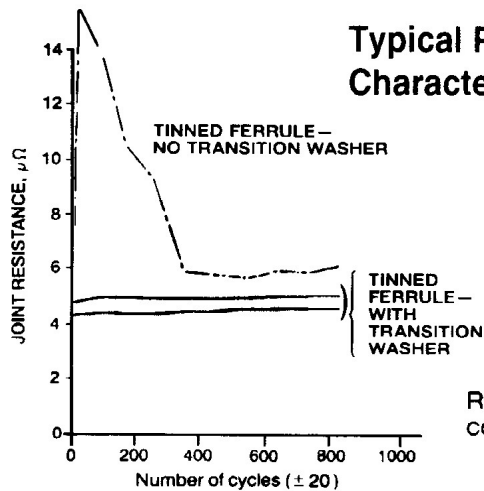

Reproduced by courtesy of C.E.R.L.

In outdoor situations, further protection is recommended. An anticorrosion mastic can be applied and this should be squeezed liberally into and around the mating faces of the joint, after the assembly has been bolted up. Re-adjustment, or dismantling and reassembly during fitting, should normally be possible using the same washers, provided that an adequate layer of grease is re-applied to the exposed surfaces of the transition washer, and the peripheral seal is restored. Any additional mastic protection previously employed should be replaced. It is recommended that where established joints have been broken, and require re-assembly, new washers are used.