

ME(T) Connector

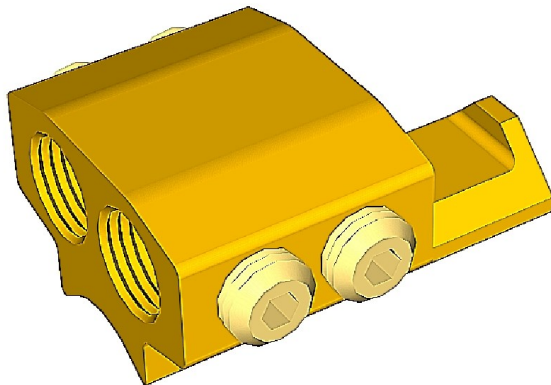

ME(T)35

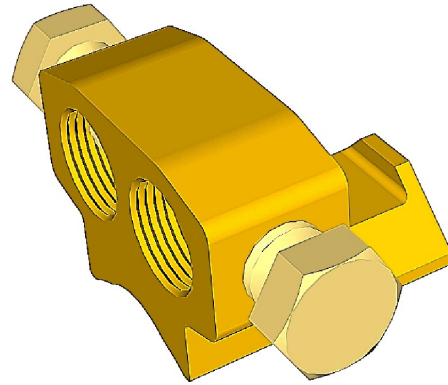

**ME(T)120
ME(T)400**

Principle Application:

Mechanical earth connection to BS 6480 LV 600/1000V impregnated paper insulated lead sheathed cable (PILC).

Connector Reference (Part Number)	Service/Mains (in ²)		Earth Bond (mm ²)	
	Min	Max	Min	Max
ME(T)35 (51807-72)	0.0225 (15mm ²)	0.06	10*	35
ME(T)120 (53485-47)	0.04 (26mm ²)	0.2	10*	70
ME(T)400 (53485-48)	0.2 (129mm ²)	0.6 (387mm ²)	10*	70

Note: For jointing other core configurations/sizes please contact Sicame Engineering Dept

The **Sicame ME(T) range** of kits provide the end user with a quick and reliable connection onto the lead sheath of a range of PILC cables.

The profiled copper alloy 'saddle' sits firmly on the lead sheath, using knitted wire tape as the interface with the assembly held firmly in place using a stainless steel worm drive clip.

The end user can now position, cut to length and prepare the earth bond BEFORE the final torque controlled connection is made within the connector.

** When jointing 10mm² earth bond, 'double up' conductor core before inserting within the cable port.*

ME(T) Connector

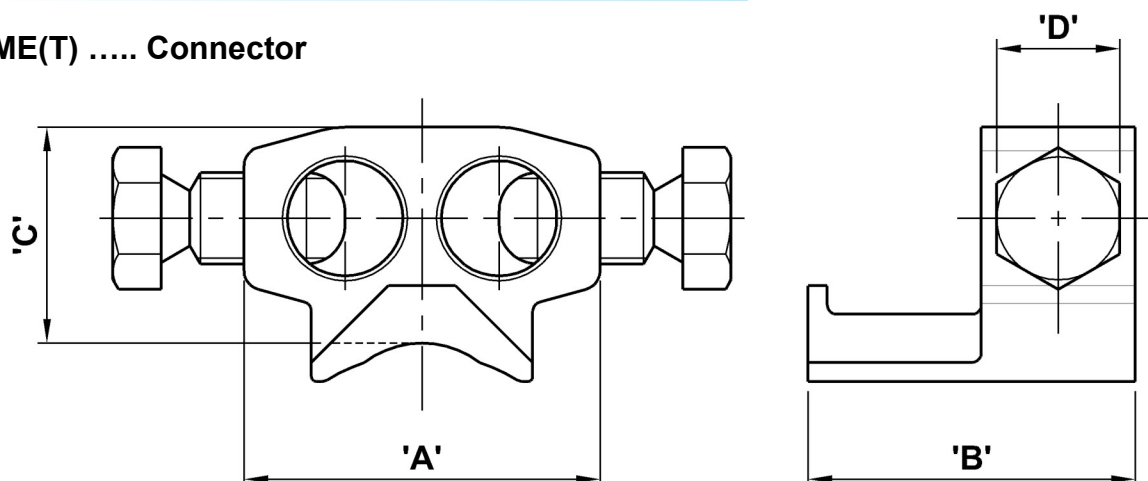

Connector Reference (Part Number)	Dimensions (mm)			
	'A'	'B'	'C'	'D'
ME(T)35 (51807-72)	29	41.5	19	2 x 3mm A/F grub screw
ME(T)120 (53485-47)	37	34	26.5	13 A/F
ME(T)400 (53485-48)	37	34	27.5	13 A/F

Material:

Copper Alloy (Body/Screw)

Test Specification:

Designed to meet the requirements of Engineering Recommendation C93.

Fitting Instructions:

1. Strip the mains/service cable to the required dimensions, as per individual Utility jointing instructions.
2. Mark the lead sheath of the position where 'saddle' is to be located and abrade surface.
3. Wrap the knitted wire tape around the lead sheath and 'tie off'.
4. Position the saddle directly on the wire tape and secure in place using worm drive clip provided.
5. Apply vinyl mastic tape to create moisture seal as per individual REC jointing instructions.
6. Position the earth bond, cut to length and prepare the end for connection into the 'saddle' - abrade the copper wires.
7. Torque tighten the shear head screw until the head shears. **(ME(T)35 do NOT shear).**